





0,5%S Fuels of 2020 – Alfa Laval Upgrade Solutions

Spyros Flessas
Regional Sales Manager
Service Operations Supervisor

MARPOL Annex VI

1st July 2010

1.00% Sulphur Cap for ECA / SECA

1st Jan 2012

3.50% Sulphur Cap Global

1st Jan 2015

0.10 % Sulphur Cap for ECA / SECA

1st Jan 2020

0.50 % Sulphur Cap Global

Complex refinery - simplified

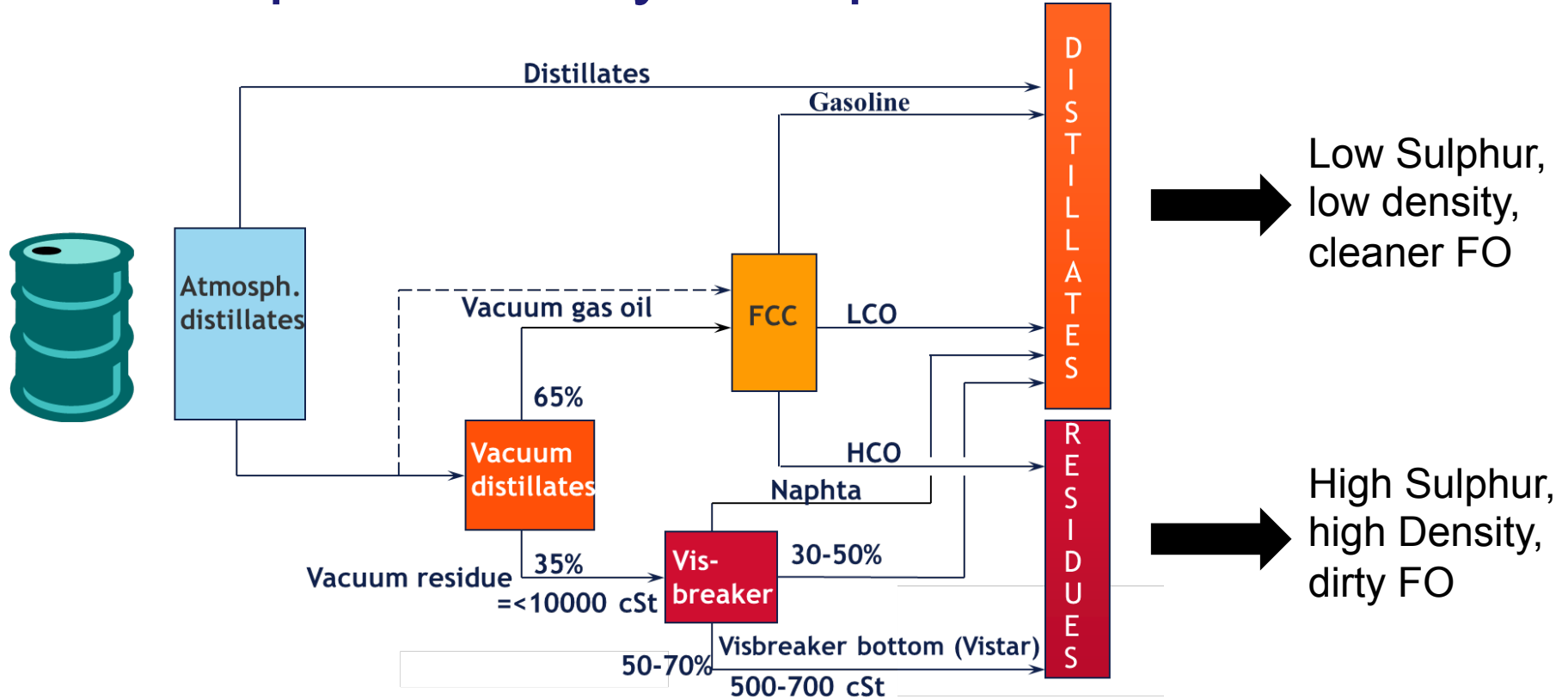

The realities of today and the future

- * Scarcity of straight run marine heavy fuels
- * Majority of residual products require significant blending to achieve required Sulphur targets
 - Available blend stocks (prioritized by cost - high to low)
 - Gas Oil
 - Light Cycle Oils
 - Slurry Oils/Cutter Stocks
 - LS components from other sources !!!

Trends in marine fuel supply

- * Oil refineries are becoming less involved in the production and supply of finished marine fuels
- * Oil traders are becoming increasingly dominant in the supply and distribution of marine fuels
- * Oil traders tend to have their own tank farms/terminals where they:
 - Import finished fuels
 - Import fuel components (from a wide variety of sources)
 - Blend finished fuels in the most cost efficient way, i.e. right up to as many specifications limits as possible
 - Supply fuels to ships

What will oil traders import?

- * Essentially anything that will enable them to produce a fuel that meets the numbers in Tables 1 or 2 of ISO8217. Meeting Clause 5 is a challenge they can be inclined to ignore
- * A fuel or a fuel components may be purchased
 - From a known refinery
 - From another trader who has blended their own imports
 - As a distress cargo at sea – this can be a cargo that has been rejected by the original purchaser because it may be off spec in some way
 - From ships de-bunkering off spec fuel
 - As a generic material such as “Cutter Stock” of unknown or partially unknown composition

Traders Supply Chain - (example.)

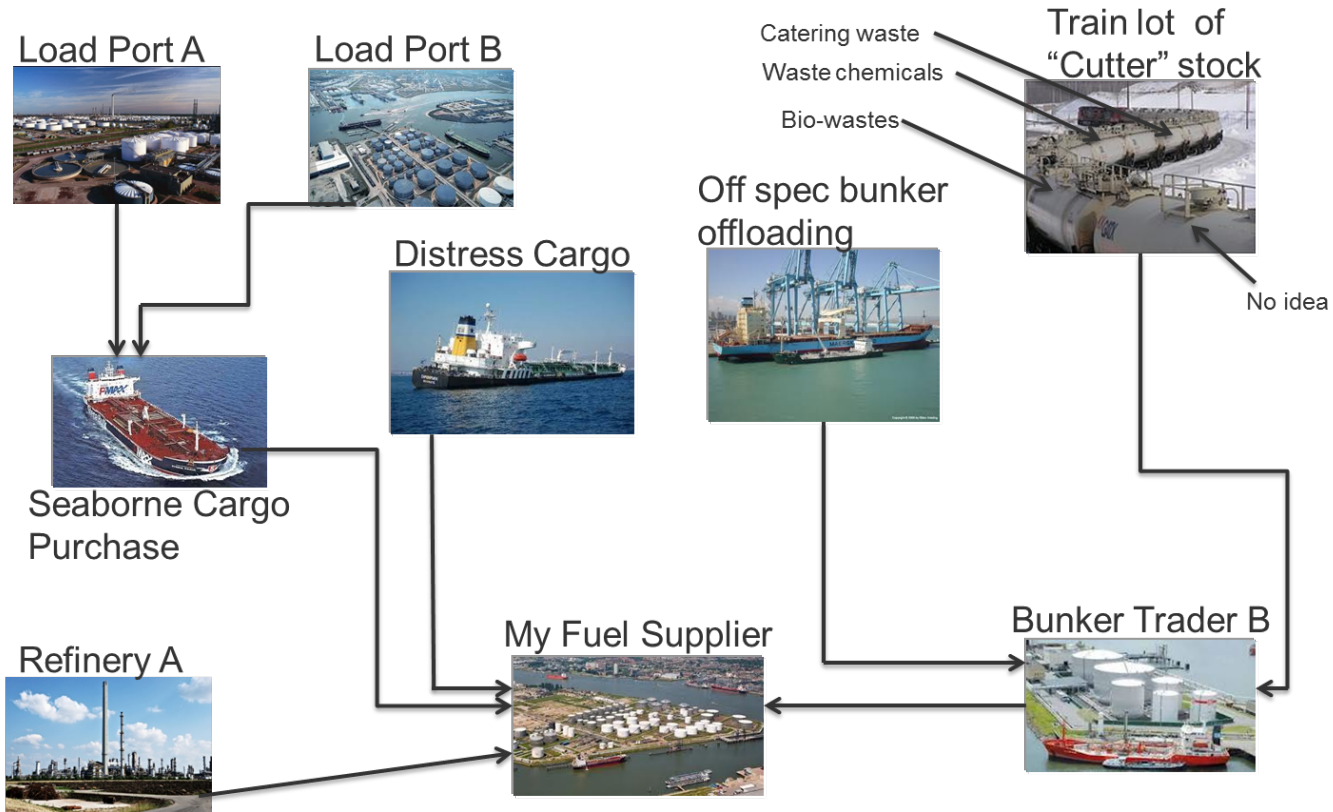

0,5% fuel examples

Test Results		
Parameter	Unit	Latest Result Novorossiysk 21 Sep 2019 1768445-1
Viscosity @ 50°C	cSt	38.48
Density @ 15°C	kg/m³	905.4
Sulphur	% (m/m)	0.14
Flash Point	°C	>67
Acid Number	mg KOH/g	<0.05
Total Sediment Acc.	% (m/m)	0.03
Micro Carbon Residue	% (m/m)	0.37
Pour Point	°C	30
Water Content	% (V/V)	0.02

0,5% fuel examples

BR PETROBRAS		BUNKER DELIVERY NOTE - BDN (Comprovante de Fornecimento a Navio - CFN)			
PETRÓLEO BRASILEIRO S.A. Av. Henrique Valadães - 28 - TORRE A - 10º andar Rio de Janeiro - RJ - Brasil CEP.: 20.231-030 TEL.: (+5521) 2196-7393 FAX: (+5521) 2196-6221 E-mail: bunker@petrobras.com.br					
FILL IN WITH BLOCK CAPITALS - WITHOUT ANY AMMENDMENT (Preencher com letras de forma - não rasurar o CFN)					
BDN NUMBER (nº do CFN)		SHIP'S NAME (nome do navio)		SHIP'S IMO NUMBER (número IMO do navio)	
PA-001217/2019				9292620	
CUSTOMER (cliente)			FLAG (bandeira)		
PETRÓLEO BRASILEIRO S.A.			A		
SHIP'S SAMPLE SEAL N° (N° laque amostra navio)		PETROBRAS'S SAMPLE SEAL N° (N° laque amostra Petrobras)		MARPOL'S SAMPLE SEAL N° (N° laque amostra Marpol)	
0018337		0018317		0018336	
SUPPLY POINT (local de fornecimento)		PORT (porto)		ORIGIN (origem)	
p2		BELEM-PA		DDT/TA/OP1/NORTE/OPBM	
PROCESS NUMBER (N° do processo)			PRODUCT (produto)		
4494			MF380		
DELIVERED QUANTITY (quantidade fornecida)					
OBSERVED VOLUME (volume ambiente)		VOLUME AT 20°C (volume a 20°C)		QUANTITY (quantidade) (xxxx.yy)	
550.452 L		543.186 L		496.906 Kg	
SPECIFIC GRAVITY AT 20 °C (densidade a 20 °C)	SPECIFIC GRAVITY AT 15 °C (densidade a 15 °C)	KINEMATIC VISCOSITY (viscosidade dinâmica)		FLASH POINT (ponto de fulgor)	SULPHUR CONTENT (teor de enxofre)
0,9148	0,9180	43,81 cSt at 50,0 °C		70,0 °C	0,45 %m/m

Accumulation

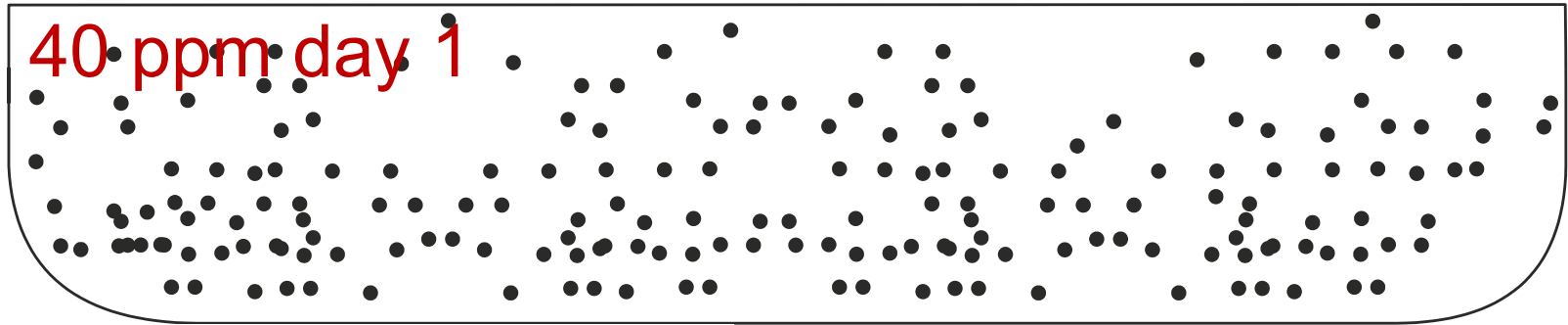

40 ppm day 1

60-70 ppm day 15

Separators - General

- * Separators with gravity disc can operate to D_{\max} : 991kg/m³
 - Average cleaning efficiency
 - Constant monitoring of use of correct gravity disc
- * ALCAP Separators can operate to D_{\max} : 1010kg/m³
 - Older models (FOPX/MFPX) have average cleaning efficiency and D_{\min} :900Kg/m³

Viscosity @ 50°C	Storage temp	Separation temp
Up to 20cSt	30°C	40°C
20 to 30cSt	30°C	50°C
30 to 40cSt	10°C above PP	60°C
40 to 50cSt	10°C above PP	70°C
50 to 70cSt	10°C above PP	80°C

Separators - Upgrade

* S-type Separators Bowl Upgrade

- Upgrading of distributor and discs of bowl
- Increase efficiency up to 30%
- Anticipate incorrect separation temperatures
- Handle more difficult fuels
- CFR approval (MAN – SL2017- 638)

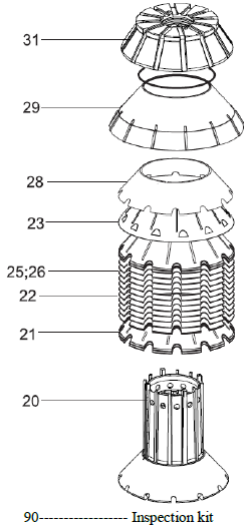

Installation efficiency

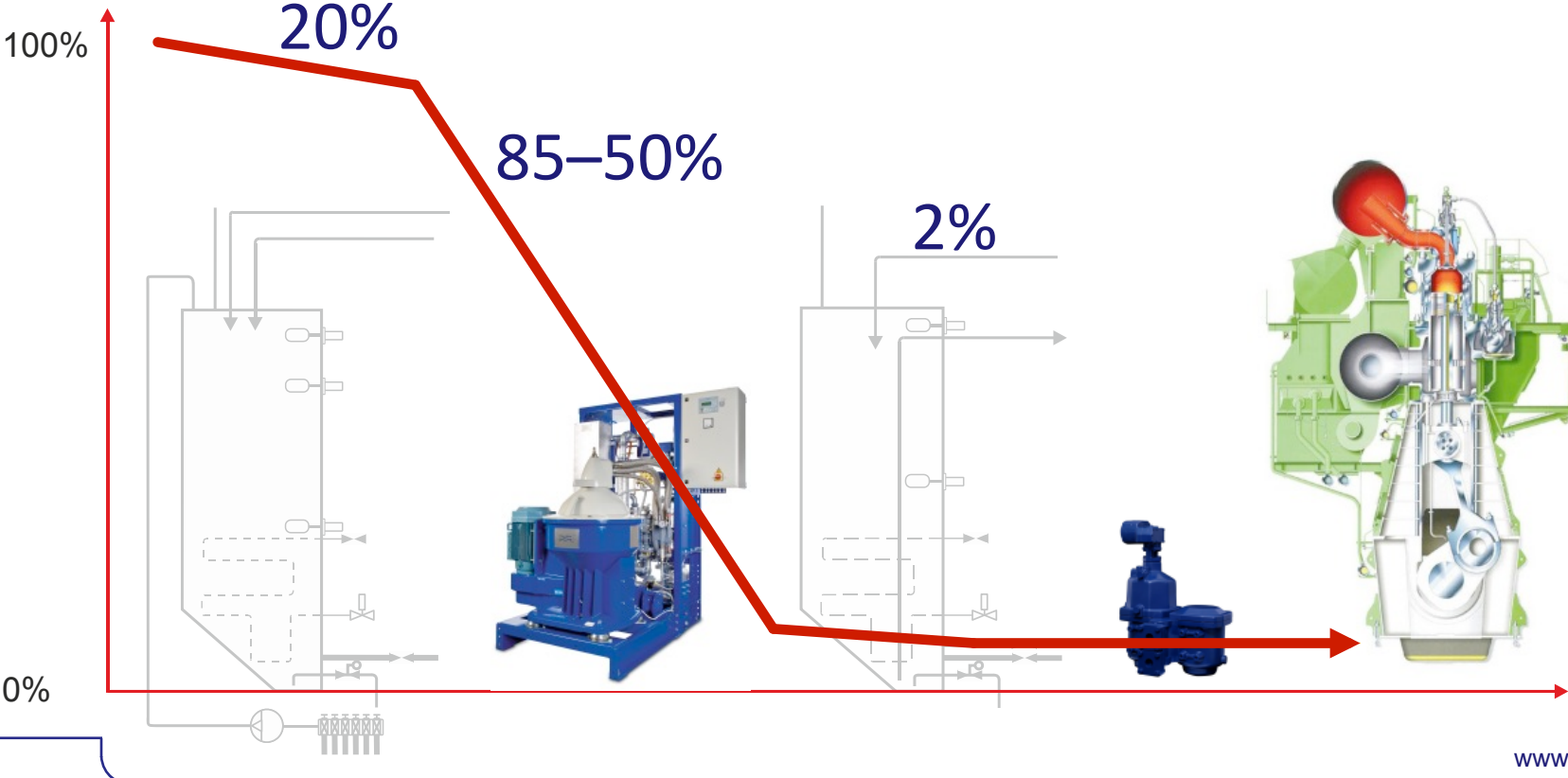

Alfa Laval CIP System

- Cleaner Bowl -> better efficiency
- Decrease service or bowl opening intervals -> less spares
- Anticipate mixing fuels incompatibilities



Alfa Laval CIP System

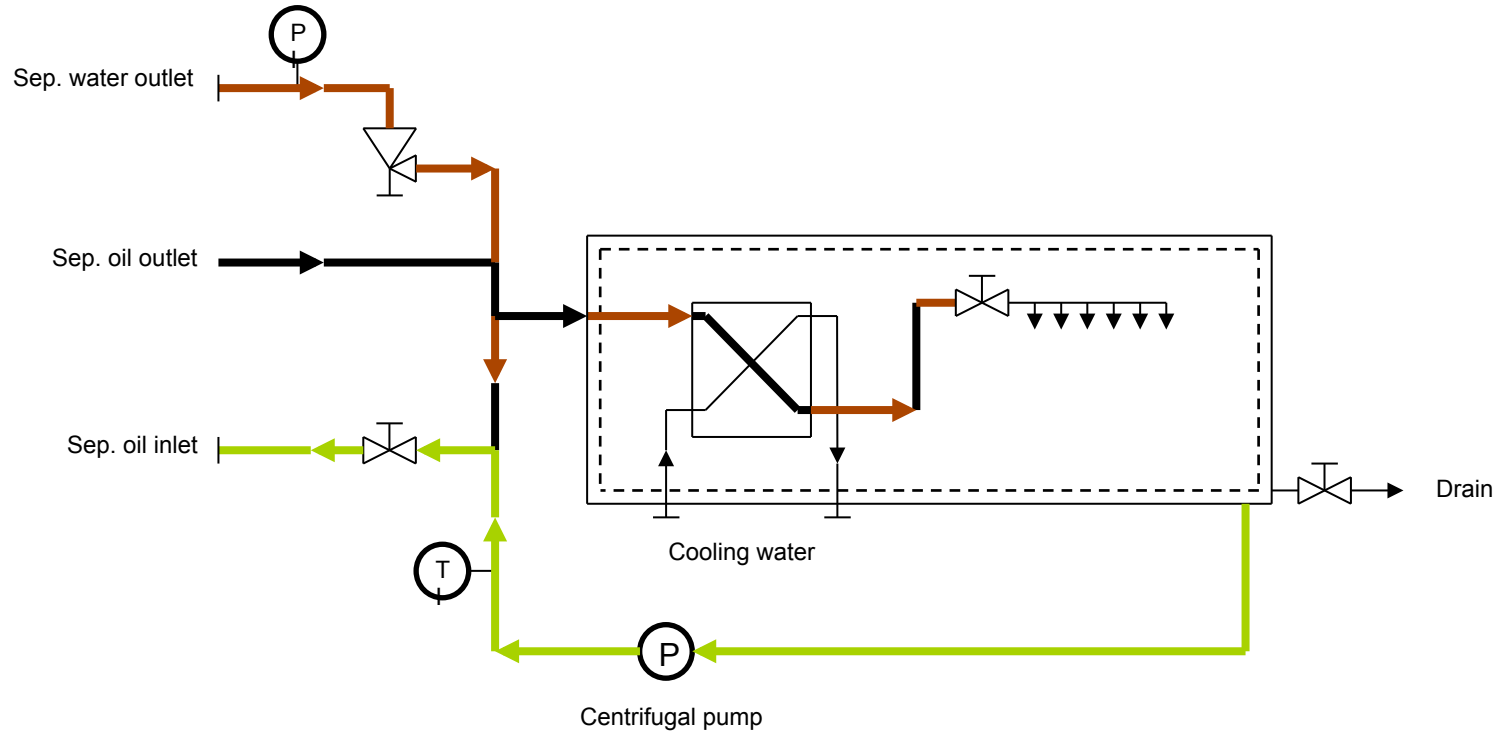

Alfa Laval Moatti FO Filters

Working principle

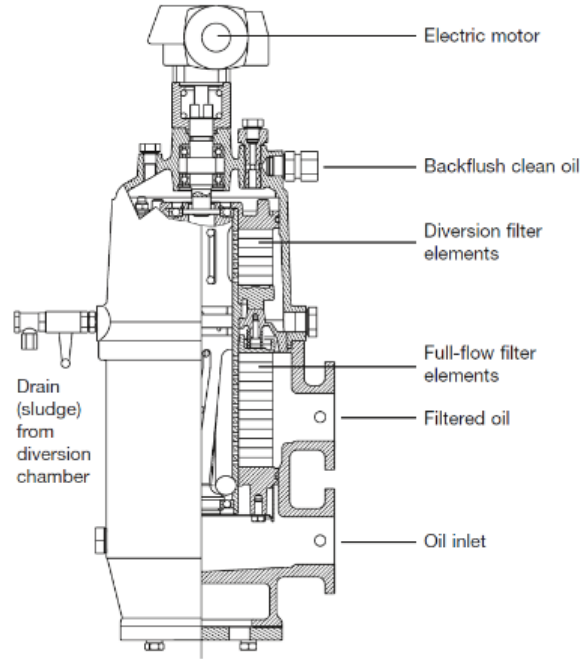

Automatic filter

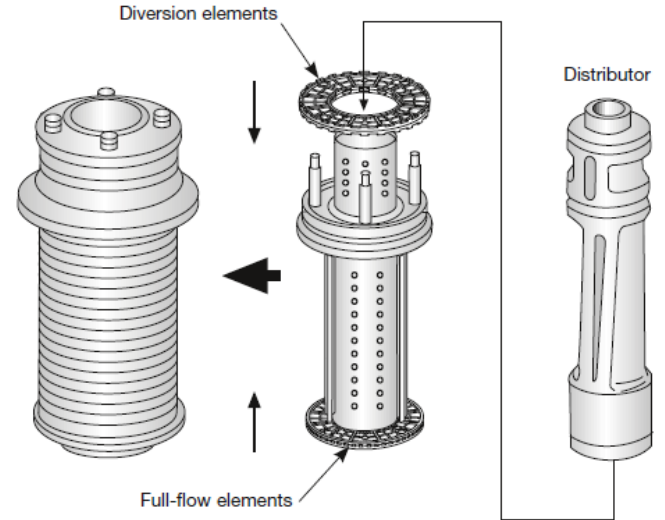

Key benefits

- * **Continuous back-flushing** prevents adhesion of solids on the filter mesh and allows a constant pressure drop,
- * **Most efficient sludge removal** on the market thanks to the diversion chamber
- * **Minimized** oil losses
 - In AL Moatti filters, backflush quantity is treated and sent back in the system, not to sludge
- * **No external power** required
 - We use a back-flushing technology – no air supply required

Alfa Laval Upgrade Solutions

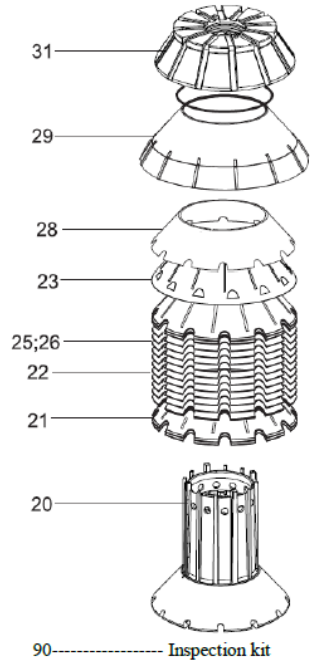

Bowl Upgrade



CIP Unit



Auto FO Filter 10µm

